

PRODUCT NUMBER

00775210

CATALOG NUMBER

7752Z

MANHOLE FRAME

LOAD RATING

HEAVY DUTY

COATING

DIPPED

ESTIMATED WEIGHT

FRAME: 170 LBS 77kg

MATERIAL SPECIFICATION

FRAME - GRAY IRON
ASTM A48 CL35B

OPEN AREA

N/A

✓ DESIGNATES MACHINED SURFACE

DRAWN

DAL

DATE

05/03/06

LAST REVISED

DEW

DATE

02/13/07

REFERENCE INFORMATION

00775213

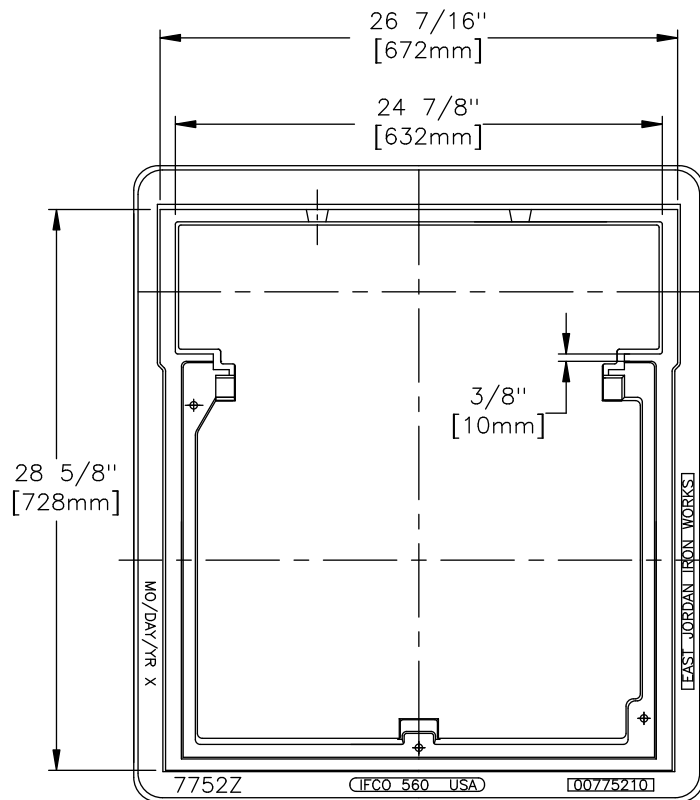

TOP VIEW

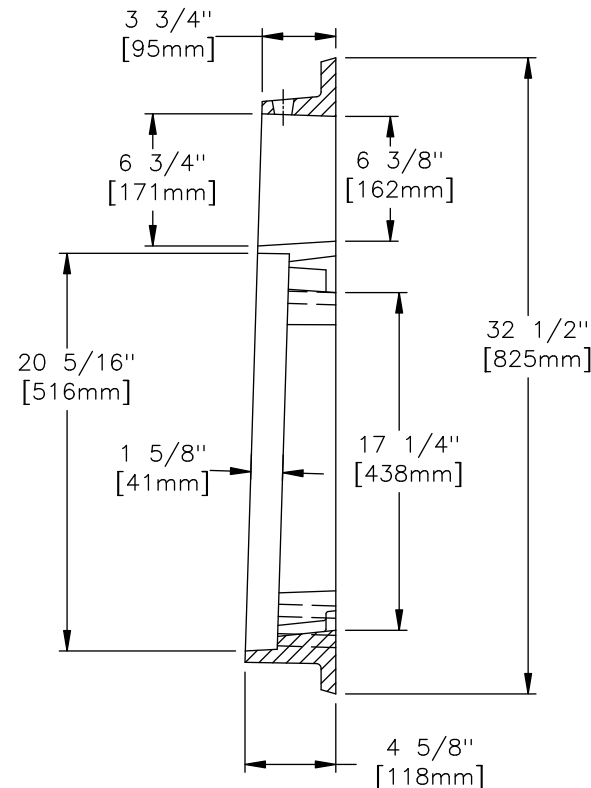

SECTION

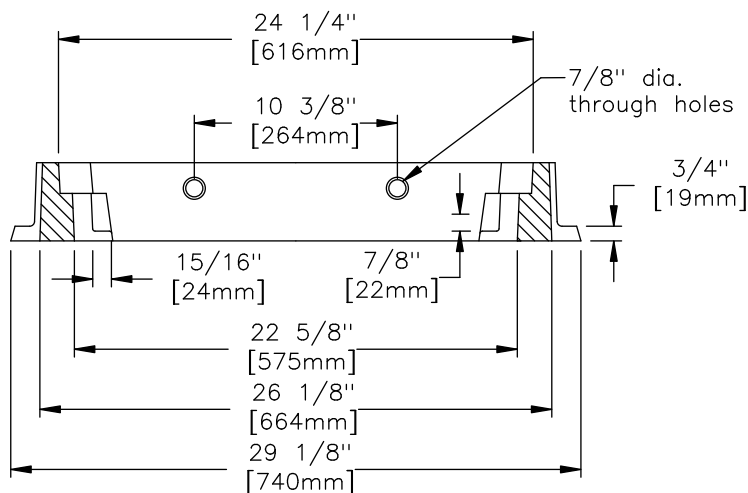

SECTION